

Instructions for Introduction Welding Contest

1. Materials:
6" x 8" x 3/8" plate
1 1/4" pipe
2. Soapstone for straight lines on plate as indicated on drawing. Use shield-arc welder. First, run two beads with 6010 1/8" welding rods, then, the next two with 7018 1/8" welding rods.
3. Cut 1 1/4" circle using pipe for a pattern anywhere on the cut strip indicated on the drawing.
4. Cut one (1) strip off of 6" x 8" piece and tack weld strip on plate as indicated on drawing the cut side showing.

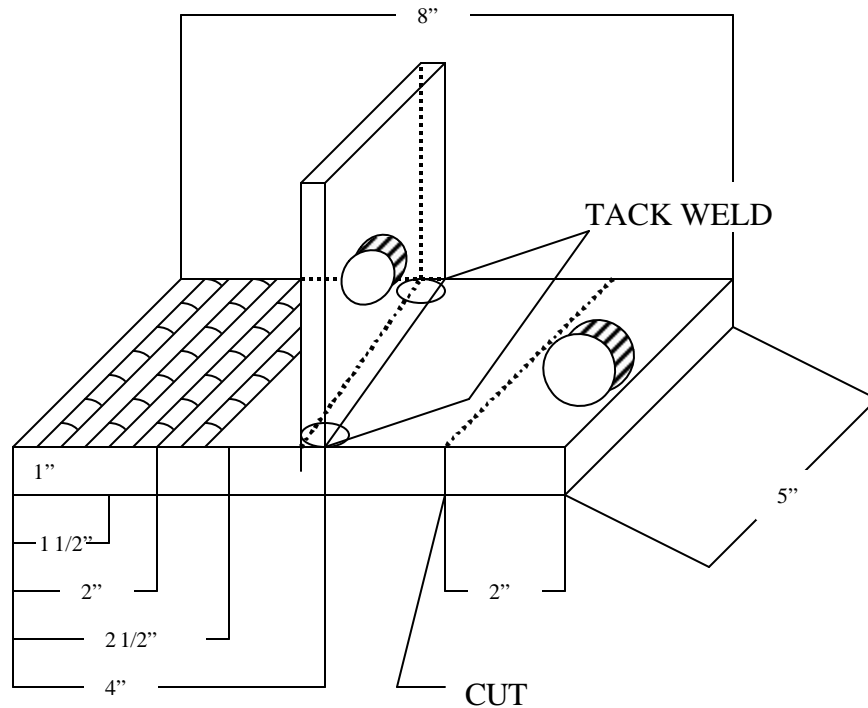

Sample Test